

# Power Cubicle Fire Extinguishing Device

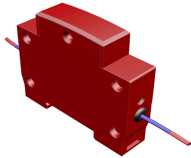

## MCCB Panel Mounted Aerosol Fire Suppression – Rapid Protection Where It Matters Most

Protect critical electrical infrastructure with compact, panel-mounted aerosol fire extinguishers designed specifically for MCCB boards and control centres. Installed directly inside the enclosure, the system provides fast, automatic fire suppression at source—extinguishing electrical fires within seconds before they escalate.

No piping, no pressure vessels, and minimal maintenance make it ideal for modern switchgear environments. The potassium-based aerosol agent interrupts combustion at a molecular level, safeguarding live equipment without water damage or residue.

Ideal for critical power systems, automation panels, and distribution boards where downtime is not an option.

**FPSP**  
Aerosol Fire Extinguisher  
AUTOMATIC

Model	AFE-20
Discharge time	≤ 6 s
Operating temperature	-50 °C to +90 °C
Protected Volume	≤ 0.11 m <sup>3</sup>
Service Life	10 years

<b>6 s</b> Fast automatic fire suppression	<b>20 g</b> Aerosol extinguishing agent
---	--

POWER HOSE  
UNIT 8 RIVERSIDE COURT - DON ROAD SHEFFIELD - S9 2TJ  
0114 3223455 INFO@FIRST-POWER.CO.UK

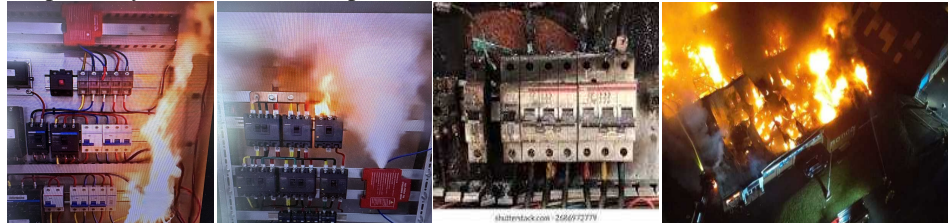

## Fire Protection

Sales 0114 322 3452  
info@first-power.co.uk

Water Treatment sites - MOD - Hospitals - Commercial - Industrial

## Fire extinguishing principle

- Heat Aerosol Fire Extinguishing Device is a new-generation formula independently developed by our company. It offers high fire suppression efficiency, is environmentally friendly, non-toxic, non-corrosive, and causes no ozone layer depletion.
- Heat Aerosol Fire Extinguishing Device is a solid chemical mixture composed of an oxidizer, reducing agent, combustion rate controller, and binder. Upon electrical or thermal activation, it undergoes an oxidation-reduction reaction, generating a large amount of condensed fire-extinguishing aerosol. The metal salt particles within the aerosol absorb significant heat at high temperatures, thereby lowering the flame temperature and inhibiting the combustion reaction. Simultaneously, under thermal influence, the vaporized metal ions and cations in the aerosol engage in affinity reactions with active radicals in the combustion process, repeatedly consuming large quantities of active species and efficiently absorbing free radicals in the flame, resulting in chemical inhibition. The presence of  $N_2$  and  $CO_2$  in the extinguishing aerosol reduces oxygen concentration in the combustion zone. Through the combined action of multiple mechanisms—both physical and chemical—the agent achieves effective fire suppression. Furthermore, the aerosol, consisting of solid particles enveloped in extinguishing gas, remains suspended and dispersed over extended periods, reaching every corner to enable highly efficient total-flooding fire suppression.

## Model and its meaning

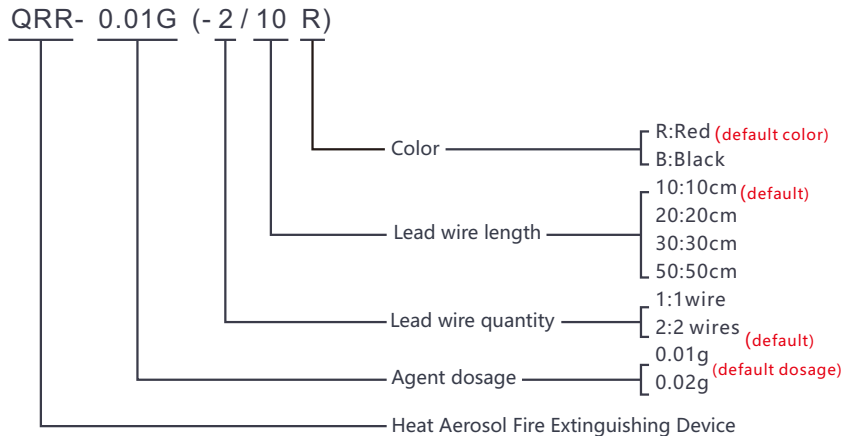

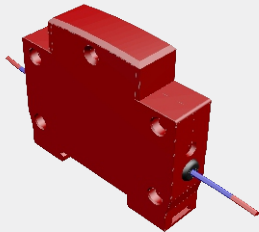
Product model	Function configuration	Technical Parameters	
 <p>QRR-0.01G(-2/10RLK)</p>	Agent Dosage	10g	20g
	Protection Space	≤0.4m <sup>3</sup>	≤0.8m <sup>3</sup>
	Discharge Time	≤6s	
	Operating Environment	-50~+90°C	
	Agent Shelf Life	10 years (for both)	
	Installation Method	Standard rail mounting /3M adhesive (for both)	
	Product Dimensions	77x18x65.5mm(for both)	
	Oxidizer Content / Barium Nitrate Content	50%~58% (for both)	
	Weight per Carton	9kg/carton	10kg/carton
	Dimensions of the box	405*247*232	

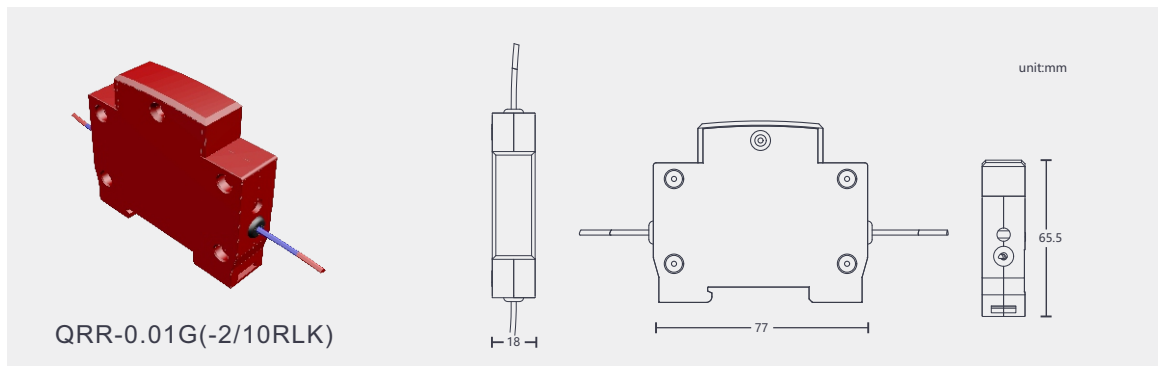

## Installation method

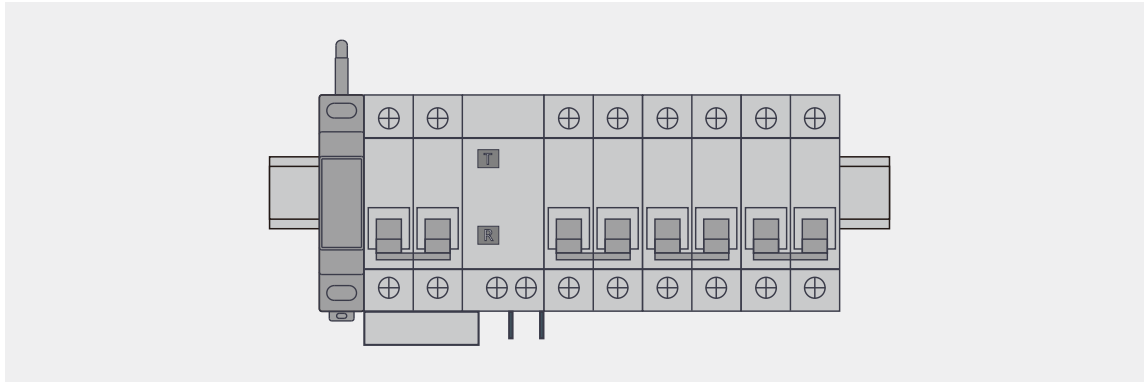

## use and maintenance

- ✔ When the fire extinguishing device is in normal working condition, the matching starting device should be inspected. The fire extinguishing device itself is maintenance-free within its validity period.

## Precautions

- ✔ During installation and use, this technical specification manual must be read carefully. Corresponding protective measures should be prepared during the installation process, and operations should be standardized.
- ✔ During installation, the nozzle of the fire extinguishing device must not face people directly.
- ✔ During installation, maintenance and overhaul, it must be ensured that the circuit will not be short-circuited. A short circuit may cause the equipment to fail or start mistakenly with a certain probability.
- ✔ Before the fire extinguishing device is discharged, it should be ensured that the nozzle is in a closed state and the nozzle protection plug does not fall off to ensure reliable performance.
- ✔ The fire extinguishing device should not be installed in environments susceptible to rain, water pouring, or with high acidity and alkalinity that is corrosive.

- ✔ After the validity period expires, the user unit should contact the supplier.
- ✔ After the fire extinguishing device is activated, please clean it in time within 24 hours and contact our company.

### **Safety tips**

- ✔ Non-professionals are prohibited from disassembling the device without authorization.
- ✔ After discharge, touching the device is forbidden before the casing cools down to prevent scalding.

### **Related Technical Standards**

- ✔ XF 499.1-2010 Aerosol Fire Extinguishing System - Part 1: Hot Aerosol Fire Extinguishing Device
- ✔ Q/JAD 002-2018 Fast-Response Hot Aerosol Fire Extinguishing Device
- ✔ EN 15276-1:2019 International Standard
- ✔ EN 15276-2:2019 International Standard

### **After-sales Service**

- ✔ Our company will provide corresponding technical support for the product in accordance with the national regulations on fire protection products.